

PLAN VIEW

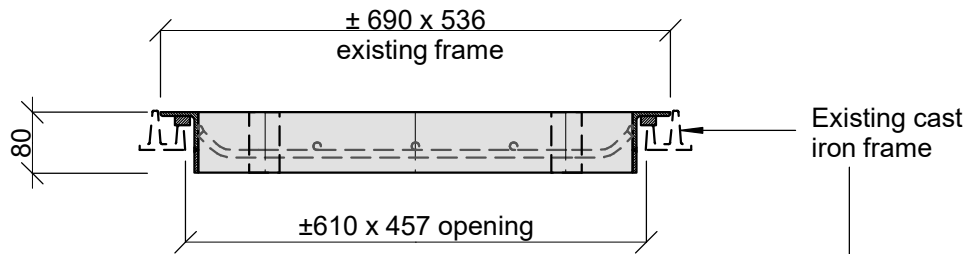

SECTION

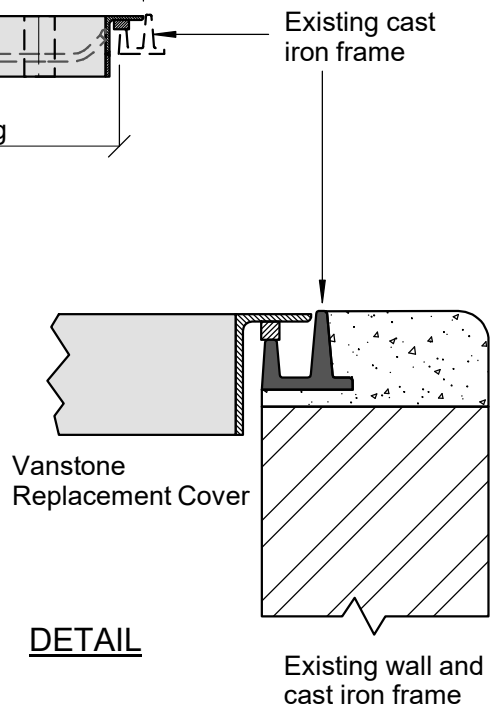

DETAIL

SPECIFICATION

SANS 558 Duty Class "M" 40kN
 Concrete: 35MPa at 28 days.
 All steel including reinforcing
 is hot dipped galvanized
 after welding.

Quantity to Cast:	1
Concrete Mix	35MPa
Mass kg ±	62
Reinforcing: To be checked by Eng	yes

**REPLACEMENT MANHOLE COVER
 TYPE 9D OPENING SIZE 610 x 457**

Product Code: P2-1590/9D

